

**SPECIFICATIONS (See notes 1 and 2)**

- Loudspeaker Type:** Ported subwoofer
- Operating Range:** 40 Hz - 150 Hz  
40 Hz - 150 Hz (+/-5dB)
- Max Input Ratings:** 300W continuous, 750W program  
35 volts RMS, 77 volts momentary peak
- Recommended Power Amplifier:**  
630W to 900W @ 4 Ohms
- Sensitivity 1W/1m:** 98 dB SPL (40 Hz - 160 Hz 1/3 octave bands)
- Maximum Output:** 123 dB SPL / 130 dB SPL (peak)
- Nominal Impedance:** 4 Ohms
- Min Impedance:** 4.4 Ohms @ 50 Hz
- Nominal -6 dB Beamwidth:**  
360° H x 360° V
- Axial Q / DI:** 1 / 0, 40 Hz - 150 Hz
- High Pass Output:** 150 Hz (1/4 inch jack)
- Recommended Signal Processing:**  
100 Hz - 150 Hz electronic crossover  
35 Hz high pass filter
- Drivers:** (2) 15", Ferrofluid-cooled
- Driver Protection:** PowerSense™ DDP
- Input Connection:** (2) Neutrik NL4MP, (2) 1/4 inch jacks
- Controls:** None
- Enclosure:** Black carpet covered Oriented Strand Board
- Enclosure Hardware:**  
(2) Steel recessed bar-handles  
(8) Interlocking corner protectors
- Mounting / Rigging Provisions:**  
(4) 5/16-18 mounting points
- Grille:** 16 gauge perforated steel, black powder coated
- Required Accessories:** None
- Supplied Accessories:** None
- Optional Accessories:**  
DSC42: digital system controller
- Dimensions (including corner protectors):**  
Height: 41.9 in. / 1065 mm  
Width (front): 20.3 in. / 515 mm  
Width (rear): 13.7 in. / 347 mm  
Depth: 18.2 in. / 463 mm
- Weight:** 89 lb. / 40.4 kg
- Shipping Weight:** 100 lb. / 45.4 kg

- 1. Sensitivity:** Free field pink noise measurement at 40 ft. (12.2m) at 20% power; extrapolated to 1 meter and an input of 2 volts RMS.
- 2. Watts:** All wattage figures are calculated using the rated nominal impedance.

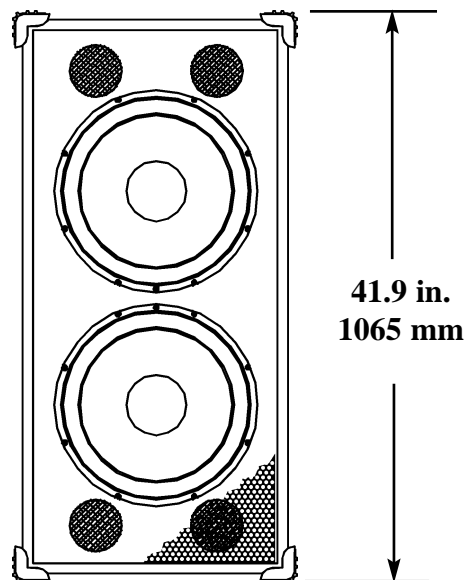

**APPLICATIONS:**

- Sound Reinforcement / Portable PA
- Clubs
- Houses of Worship
- Sport Facilities & Health Clubs
- Industrial A/V
- Keyboard Systems

**FEATURES:**

- 15" Ferrofluid-cooled Woofers
- Four Ports for Efficient Bass Output
- PowerSense™ DDP Circuit with Front/Rear Indicators
- Tall Trapezoidal Enclosure
- Steel Bar-Handles and Input Panel
- Black-Carpeted Exterior finish

**DESCRIPTION**

The XLT55 is a versatile high-efficiency subwoofer designed for installation with any of the XLT full-range loudspeaker systems for extended deep bass output with exceptional punch. The black-carpeted OSB enclosure and black perforated steel grille present an attractive and rugged package. The XLT55 subwoofer has an integral 150 Hz high pass output filter. It can be used to directly feed XLT41 or XLT43 full range systems, thus requiring only one amplifier channel to power both systems. When used with larger XLT full-range systems, a separate amplifier channel is recommended for each system. Five year limited warranty.

**FREQUENCY RESPONSE**

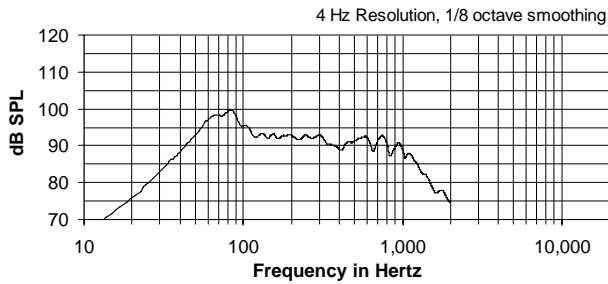

**IMPEDANCE**

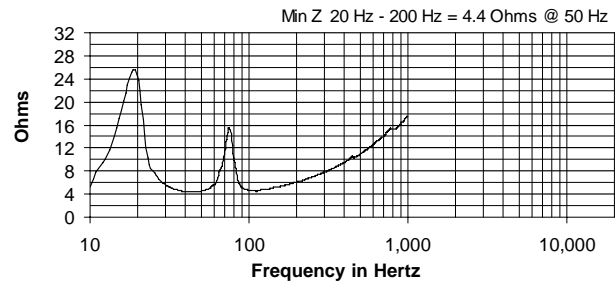

**DIMENSIONS**

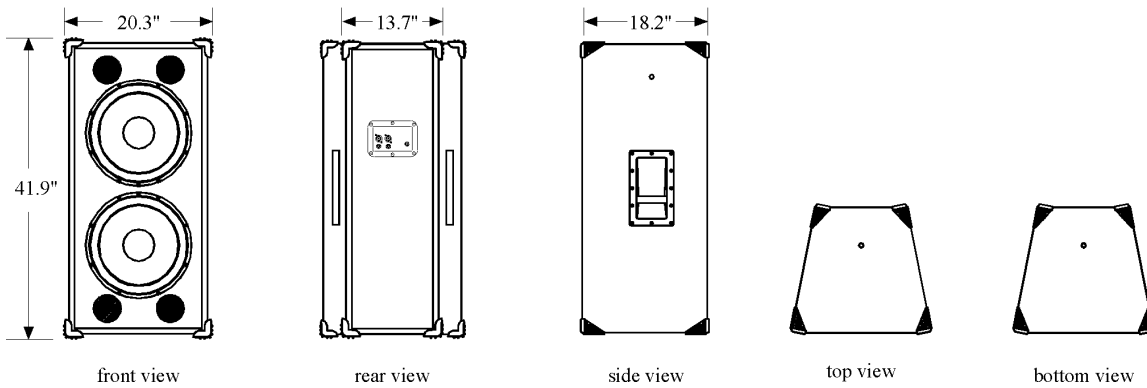

**ARCHITECTS' AND ENGINEERS' SPECIFICATIONS**

The loudspeaker system shall be a subwoofer of bass reflex trapezoidal design with two 15 in. Ferrofluid-cooled woofers. Drivers shall be connected to integral over-current protection circuitry using high positive current coefficient resistors as well as to an integral high pass filter at 150 Hz connected to high pass output jack. There shall be two NL4MP jacks and two 1/4" phone jacks. The loudspeaker enclosure shall be black carpeted Oriented Strand Board (OSB) with a 16 gauge perforated steel grille. The system shall have an amplitude response of 40 Hz to 150 Hz (+/- 5 dB), input capability of 35V RMS, 98 dB sensitivity at one meter and 2V / 4 ohms nominal impedance. The nominal dispersion shall be omni-directional throughout the operating range. The loudspeaker shall be 41.9 in. (1065 mm) H x 20.3 in. (515 mm) W (front) x 13.7 in. (347 mm) W (rear) x 18.2 in. (463 mm) D and weigh 89 lbs (40.4 kg).