

SPECIFICATIONS (See notes 1 and 2)

Loudspeaker Type: 2-way, Full-range, bass ported

Operating Range: 50 Hz - 18 kHz

50 Hz - 18 kHz (+/-5dB)

Max Input (Passive):

400W continuous, 1000W Program

40 volts RMS, 89 volts momentary peak

Recommended Power Amplifier:

830W to 1200W @ 4 Ohms

Max Inputs (Biamp):

LF: (Same as for Passive mode)

Recommended LF Power Amp:(Same as for Passive mode)

HF: 50W continuous, 125W program

20 volts RMS, 45 volts momentary peak

Recommended HF Power Amp: 100W to 150W @ 8 Ohms

Sensitivity 1W/1m:

98 dB SPL (50 Hz - 16 kHz 1/3 octave bands)

98 dB SPL (250 Hz - 4 kHz speech range)

Maximum Output: 124 dB SPL / 131 dB SPL (peak)

Nominal Impedance (passive): 4 Ohms

Min Impedance: 3.2 Ohms @ 145 Hz

Nominal Impedances (Biamp): LF: 4 Ohms, HF: 8 Ohms

Nominal -6 dB Beamwidth:

80° H (+0° / -39°, 2 kHz - 10 kHz)

35° V (+1° / -19°, 2 kHz - 10 kHz)

Axial Q / DI:

26.1 / 14.2, 2 kHz - 10 kHz

Crossover Frequency: 1.8 kHz

Recommended Signal Processing: 40 Hz high pass filter

Drivers:

LF (2) 15", Ferrofluid-cooled

HF (1) 1" exit, titanium diaphragm

Driver Protection: PowerSense™ DDP

Input Connection: (2) Neutrik NL4MP, (2) 1/4 inch jacks

Controls: Passive / Biamp switch
2 position HF level switch

Enclosure: Black carpet covered Oriented Strand Board

Enclosure Hardware:

(2) Steel recessed bar-handles

(8) Interlocking corner protectors

Mounting / Rigging Provisions:

(4) 5/16-18 mounting points

Grille: 16 gauge perforated steel, black powder coated

Required Accessories: None

Supplied Accessories: None

Optional Accessories: None

Dimensions (including corner protectors):

Height: 41.9 in. / 1065 mm

Width (front): 20.3 in. / 515 mm

Width (rear): 13.7 in. / 347 mm

Depth: 18.2 in. / 463 mm

Weight: 102 lb. / 46.3 kg

Shipping Weight: 112 lb. / 50.8 kg

1. Sensitivity: Free field pink noise measurement at 20 ft / 6.1 m at 25% power; extrapolated to 1 meter and an input of 2 volts RMS.

2. Watts: All wattage figures are calculated using the rated nominal impedance.

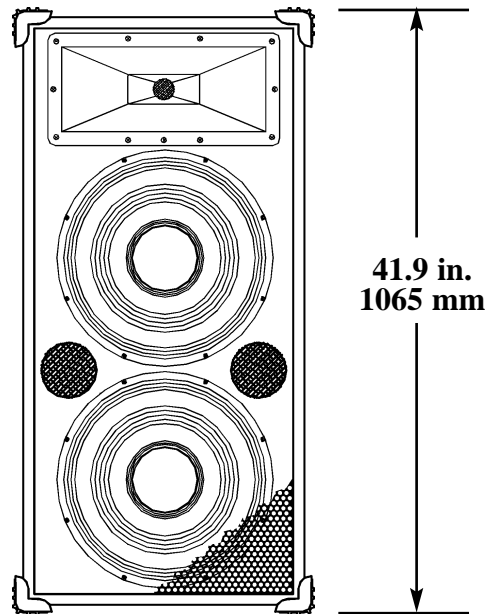

APPLICATIONS:

- Sound Reinforcement / Portable PA
- Clubs
- Houses of Worship
- Sport Facilities & Health Clubs
- Industrial A/V
- Keyboard Systems

FEATURES:

- 1" Titanium HF Driver
- Switchable Passive / Biamp Modes
- HF Level Switch
- PowerSense™ DDP Circuit with Front/Rear Indicators
- Tall Trapezoidal Enclosure For HF Projection
- Steel Bar-Handles and Input Panel
- Black-Carpeted Exterior

DESCRIPTION

The XLT47 is a versatile, two-way full-range bass reflex loudspeaker system with two Ferrofluid-cooled 15" LF drivers engineered for use in medium-sized club and performance applications. The black-carpeted OSB enclosure and black perforated steel grille present an attractive and rugged package. Its 42" height allows sound to project over the audience in many situations that would require a speaker stand. Features an over-drive indicator light and a passive / biamp switch on the input panel, PowerSense protection circuitry and a Ferrofluid cooled woofer. Five year limited warranty.

FREQUENCY RESPONSE

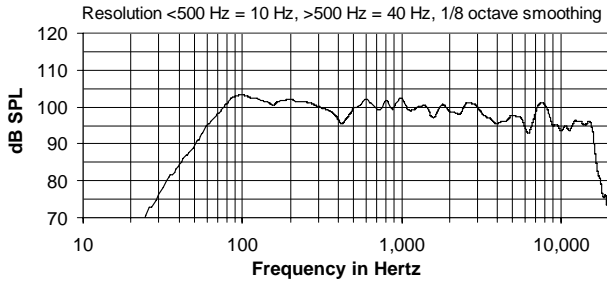

IMPEDANCE

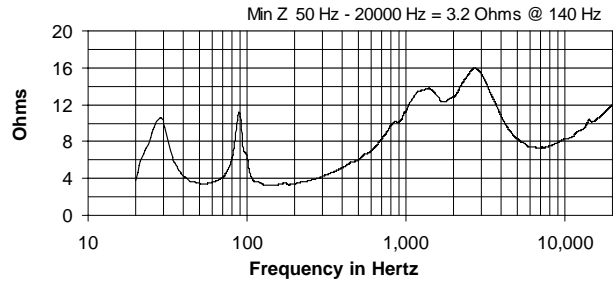

BEAMWIDTH

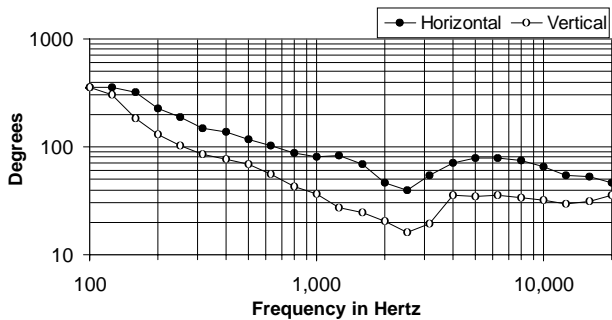

AXIAL Q

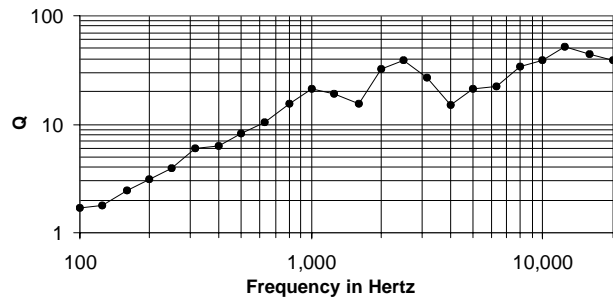

DIMENSIONS

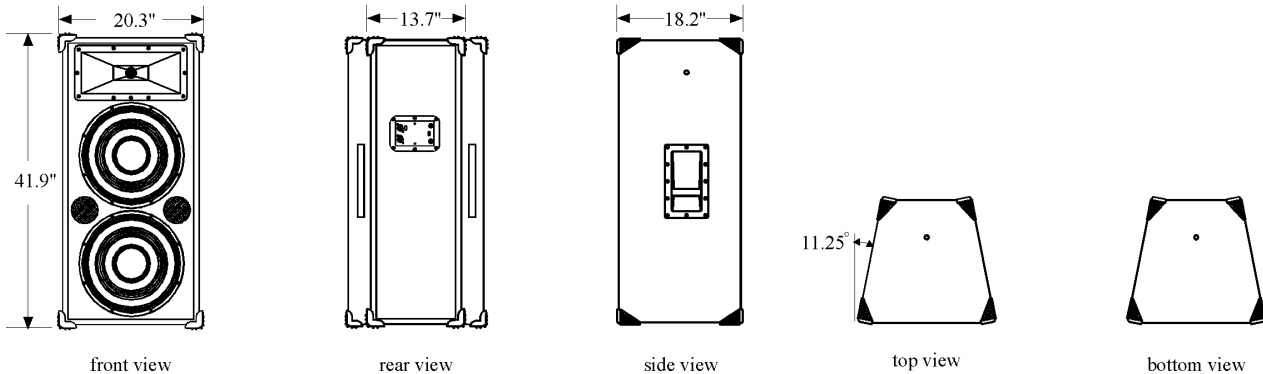

ARCHITECTS' AND ENGINEERS' SPECIFICATIONS

The loudspeaker system shall be a two-way, full-range bass reflex trapezoidal design with two 15 in. Ferrofluid-cooled woofers and one 1 in. exit HF driver with a titanium diaphragm mounted to a 90° HF fiberglass horn. Drivers shall be connected to an integral crossover with a crossover frequency of 2 kHz and integral over-current protection circuitry using high positive current coefficient resistors. There shall be two NL4MP connectors and two 1/4" phone jack connectors with a switch for passive or biamplified connection and rear-facing LED over-power indicator light. The loudspeaker enclosure shall be black carpeted Oriented Strand Board (OSB) with a 16 gauge perforated steel grille. The system shall have an amplitude response of 50 Hz to 18 kHz (+/- 5 dB), input capability of 40V RMS, 98 dB sensitivity at one meter and 2V / 4 ohms nominal impedance. The nominal dispersion shall be 80°H x 35° V from 2 kHz to 10 kHz. The loudspeaker shall be 41.9 in. (1065 mm) H x 20.3 in. (515 mm) W (front) x 13.7 in. (347 mm) W (rear) x 18.2 in. (463 mm) D and weigh 102 lbs (46.3 kg).