

MODEL SM81 UNIDIRECTIONAL CONDENSER MICROPHONE



OVERVIEW

The Shure Model SM81 is a high-quality, unidirectional condenser microphone designed for studio recording, broadcasting, and sound reinforcement. Its wide frequency response, low noise characteristics, and low RF susceptibility have made it a standard for applications involving acoustic instruments, especially guitar, piano, and cymbals.

FEATURES

- 20 Hz to 20 kHz frequency response
- Flat response curve for accurate reproduction of sound sources
- Low noise and high output clipping level
- Low distortion over a wide range of load impedances
- Cardioid polar pattern, uniform with frequency and symmetric about axis, providing maximum rejection and minimum coloration of off-axis sounds

SPECIFICATIONS

Type

Condenser (electret bias)

Frequency Response

20 to 20,000 Hz

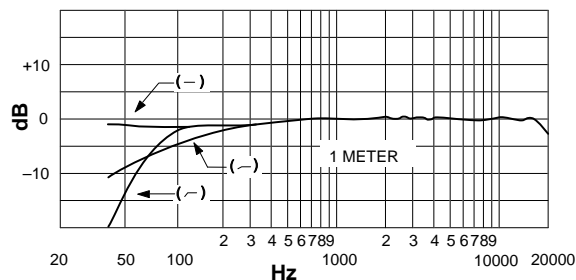

TYPICAL FREQUENCY RESPONSE

The SM81 is ruggedly constructed. It operates on phantom power and performs over a wide range of temperatures and humidity conditions. It is furnished with a swivel adapter, attenuator-switch lock, foam windscreen, and case for carrying and storage. Other accessories are available.

- Low RF susceptibility
- Selectable low-frequency response: flat, 6 or 18 dB/octave rolloff
- 0 dB/10 dB lockable attenuator switch
- Phantom powering (DIN 45 596 voltages of 12 to 48 Vdc)
- Rugged steel construction for durability
- Field-usable over wide range of temperature and humidity conditions

Polar Pattern

Cardioid (unidirectional) response—uniform with frequency, symmetrical about axis (see Figure NO TAG)

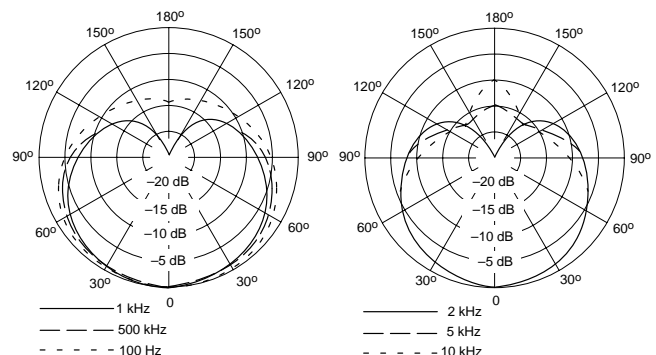

TYPICAL POLAR PATTERNS

Output Impedance

Rated at 150 ohms (85 Ω actual)
 Recommended minimum load impedance: 800 Ω (May be used with loads as low as 150 Ω with reduced clipping level)

Output Configuration and Connector

Balanced, transformer-coupled output; male XLR connector

Sensitivity (at 1,000 Hz)

Open Circuit Voltage -45 dBV/Pascal (5.6 mV)
 (1 Pascal = 94 dB SPL)

Clipping Level (at 1,000 Hz)

800 Ω Load -4 dBV (0.63 V)
 150 Ω Load -15 dBV (0.18 V)

Total Harmonic Distortion

Less than 0.5% (131 dB SPL at 250 Hz into 800 Ω load)

Maximum SPL (at 1,000 Hz)

800 Ω load 136 dB (attenuator at 0)
 146 dB (attenuator at -10)
 150 Ω load 128 dB (attenuator at 0)
 138 dB (attenuator at -10)

Hum Pickup

-3 dB equivalent SPL in a 1 mOe field (60 Hz)

Self-Noise (equivalent sound pressure levels; measured with true rms voltmeter)

16 dB typical, A-weighted
 19 dB typical, weighted per DIN 45 405

Signal-to-Noise Ratio

78 dB (IEC 651)* at 94 dB SPL
 *S/N ratio is difference between microphone output at 94 dB SPL and microphone self-noise A-weighted.

Overvoltage and Reverse Polarity Protection

Max. external voltage applied to pins 2 and 3 with respect to pin 1 + 52 Vdc

Reverse polarity protection 200 mA max.
 (diode-clamped)

Polarity

Positive pressure on diaphragm produces positive voltage on pin 2 relative to pin 3

Cartridge Capacitance

54 pF

Low Frequency Response Switch Positions

Flat; -6 dB/octave below 100 Hz; -18 dB/octave below 80 Hz

Attenuator Switch Positions (Lockable)

0 or -10 dB

Power

Supply Voltage 11 to 52 Vdc, positive, pins 2 and 3
 Current Drain 1.2 mA max.

Environmental Conditions**Temperature:**

Storage -29° to 74° C
 (-20° to 165° F)
 Operating -6.7° to 49° C
 (20° to 120° F)

Humidity:

Storage 0-95% relative humidity at room temperature (72° to 80° F, 22° to 27° C)

Case

Steel construction with vinyl metallic paint finish and stainless steel screens

Weight

Net 230 grams (8 oz)