

For toms, snares and percussion instruments, no other microphone stands up to the performance and versatility of the new Shure Beta 98D/S.

The Beta 98D/S is a high performance mini-condenser microphone designed to excel at professional sound reinforcement or recording. Its ultra-uniform supercardioid pickup pattern provides high gain before feedback and excellent rejection of unwanted noise. In addition, an optional cardioid cartridge lets you easily adapt the mic to different applications.

As the successor to the popular SM98A, the Beta 98D/S features several notable improvements. Dynamic range is 4 dB greater, as is headroom, while maximum SPL is 5 dB higher (now 160 dB!). Physically, the mic utilizes a thicker, beefier Triple-Flex® cable (detachable).

With the unique A98D microphone drum mount (supplied), no other rim-mounted microphone stays more securely in place. This hardware has been redesigned for quicker, more secure, rim-mounting without the need for a drum key. Its flexible gooseneck lets you position the mic in practically any configuration, so you get a virtually unlimited choice of sound options. Its unobtrusive design and compact size help the Beta 98D/S reduce stage clutter to an absolute minimum. (The microphone is also available without the drum mount - model Beta 98/S.)

And because it bears the Shure name, you can be certain that the Beta 98D/S will withstand just about any abuse it may run across and keep delivering great sound.

## technical specifications

---

### Frequency Response Curve

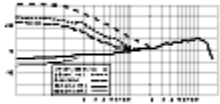

## Beta 98D/S™

Snare|Tom Microphone

20Hz to 20kHz



### Suggested Applications

Rack/Floor Toms

Snare Drum

Congas

### GENERAL

The Shure A98D mounts Shure BETA 98/S or SM98A microphones on a drum or cymbal. The gooseneck adapter can be inserted into the horizontal or vertical slots of the clamp for optimum flexibility in microphone placement.

The clamp fits drum rims measuring from 1/2-in. (12.7 mm) to 2 1/4-in. (57.2 mm) in height, or on cymbal stands measuring from 3/8-in. (9.5 mm) to 1 1/8-in. (28.6 mm) in diameter.

### DRUM RIM MOUNTING

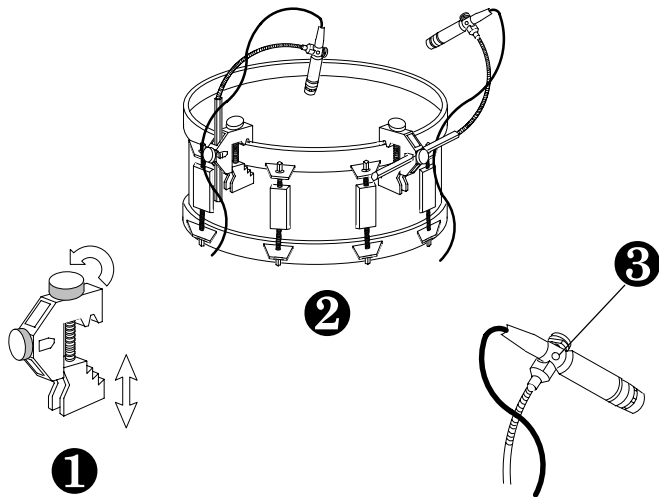

### CYMBAL STAND MOUNTING

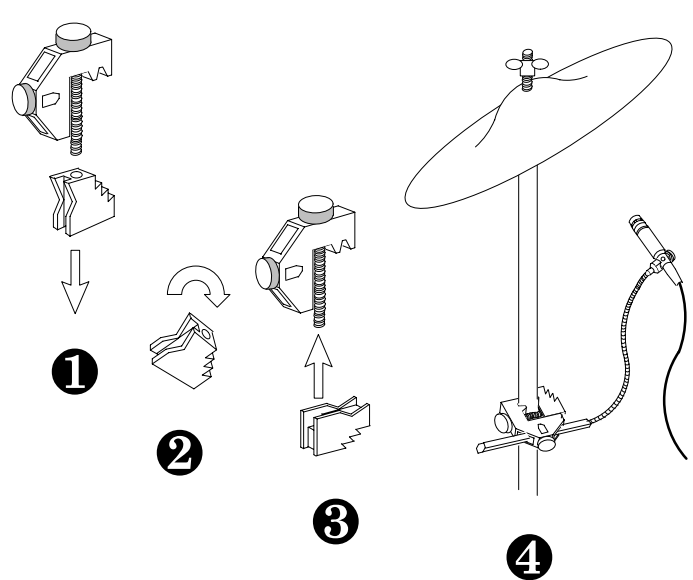

**WARNING:** Do NOT tighten the thumbscrew on the plastic section of the connector as this could cause damage.

**NOTE:** To minimize potential noise or damage, position the microphone outside the drummer's range of stick movement and cymbal movement.

### REPLACEMENT PARTS

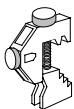

Clamp Assembly ..... RPM618



Jaw ..... 32A866