

DIGITAL RECORDING CONSOLE

O2R

Version 2



YAMAHA

The world's most popular affordable, high-performance, full-featured digital recording console now sets an even higher standard.

Yamaha's award-winning 02R Digital Recording Console is now available with Version 2 software. Hailed the world over for setting the standard in cost-effective professional digital mixing, 02R Version 2 raises that standard by including a long list of new features designed to greatly increase productivity, further decrease the need for peripheral components, and even provide an all-in-one sound processing platform for DVD projects.

Still provided are all the powerful features that have made the 02R the first choice for professional project and post production studios relying on TASCAM, ADAT, AES/EBU and YAMAHA digital interface formats—not to mention the versatile cascading options and many on-board processing functions which make the 02R an ideal live mixing and recording console.

These include uncompromising features like a versatile 40-input/8-bus configuration, individual channel PEQ and dynamics processors, effects libraries, scene snapshots and full on-board automation for recording and mixdown sessions, and pristine sound quality plus fast processing power from twin RISC CPUs and 32-bit signal processing LSIs.

02R Version 2 includes a long list of additional features resulting from extensive consultation with many 02R users worldwide. Added are on-board 24-bit recording capability, various surround panning options, off-line copy-and-paste editing, timecode offset and timecode "capture" for quick location of specific points in a song. Plus, now there's touch sense fader editing which allows a fader to be instantly updated by simply moving it. There's also much more versatile I/O assigning of input patching and slot and Aux output selection, as well as MIDI remote and MIDI control assign, on-board MS stereo decoding, bus channel pairing, more flexible routing assignment and fader grouping, more scene memories, automatic fader start and stop of MD, DAT and CD—and much, much more.

Options

CD8-TDII



CD8-AT



CD8-AE



CD8-AE-S



CD8-AD



CD8-AD-S



CD8-CS KIT



Options	Model	Connector	
I/O Interface Card	TASCAM	CD8-TDII	D-sub 25pin x1
	ADAT	CD8-AT	OPTICALx2
	AES/EBU	CD8-AE	XLR-3-31 type x4, XLR-3-32 Type x4
		CD8-AE-S	D-sub 25pin x1
	YAMAHA	CD8-Y	D-sub 25pin x1
AD/DA Interface Card	CD8-AD	TRS Phone Jack x 16	
	CD8-AD-S	TRS Phone Jack x 8	

Options	Model	Connector
Digital Cascade Kit *	CD8-CS KIT	D-sub 25pin x1
Peak Meter Bridge	MB202	D-sub 15pin
Memory Expansion Kit (for Automation)	ME4M	_____
Wood Side Pads	W02SP	_____

*...2xDigital Cascade Card, 1xD-sub Cascade Cable

Analog Console Illustration

Input Functions

MIC/LINE IN Ch 1-8 w/Insert I/O	MIC/LINE IN Ch 9-16	LINE IN Ch 17-24	TAPE RETURN Ch 1-16	Effect RETURN 1,2(L,R)
48V, A/B, PEEK, SIGNAL, GAIN, PHASE, DELAY, ATT	48V, A/B, PEEK, SIGNAL, GAIN, PHASE, DELAY, ATT	48V, A/B, PEEK, SIGNAL, GAIN, PHASE, DELAY, ATT	PEAK, SIGNAL, DELAY, ATT	PEAK, SIGNAL, DELAY, ATT
IN, OUT, GR, THR, RATIO, O. GAIN, KNEE, ON, TYPE, DYNAMICS	IN, OUT, GR, THR, RATIO, O. GAIN, KNEE, ON, TYPE, DYNAMICS	IN, OUT, GR, THR, RATIO, O. GAIN, KNEE, ON, TYPE, DYNAMICS	IN, OUT, GR, THR, RATIO, O. GAIN, KNEE, ON, TYPE, DYNAMICS	IN, OUT, GR, THR, RATIO, O. GAIN, KNEE, ON, TYPE, DYNAMICS
HI, LO, MID, LFF, HPF, EQ ON	HI, LO, MID, LFF, HPF, EQ ON	HI, LO, MID, LFF, HPF, EQ ON	HI, LO, MID, LFF, HPF, EQ ON	HI, LO, MID, LFF, HPF, EQ ON
AUX 1-8	AUX 1-8	AUX 1-8	AUX 1-8	AUX 1-8
PAN, ROUTING, ODD, EVEN, ON	PAN, ROUTING, ODD, EVEN, ON	PAN, ROUTING, ODD, EVEN, ON	PAN, ROUTING, ODD, EVEN, ON	PAN, ROUTING, ODD, EVEN, ON
MUTE, SOLO	MUTE, SOLO	MUTE, SOLO	MUTE, SOLO	MUTE, SOLO

Automix Master & Monitor Functions

AUTOMIX/MEMORY Module	AUX MASTER 1-8/ BUS MASTER 1-8	Stereo MASTER	MONITOR Module
L, R STEREO METER, 30, 300, 25, 24 FRAMES, SMPTE, MTC, MDI, CLOCK, TC INPUT, TIME DISPLAY, AUTOLOCK, REC, PLAY, STOP, ABORT, AUTOMIX	METER, METER, AUX 1-8, IN, OUT, GR, THR, RATIO, O. GAIN, KNEE, ON, TYPE, DYNAMICS	BUS 1-8, AUX 1-8, NOISE, 10K, 1K, 100, OSC ON, OSCILLATOR, TALKBACK, ATT, IN, OUT, GR, THR, RATIO, O. GAIN, ATK, KNEE, ON, TYPE, DYNAMICS	2TR IN A1, 2TR IN A2, 2TR IN D1, 2TR IN D2, 2TR IN D3, AUX 1-8, ST, MONO, DUAL, TO LEVEL, FROM LEVEL, C-R, AUX 1-8, C-R, ST, TO LEVEL, FROM LEVEL, STUDIO, RECORDING, MIXDOWN, SOLO STATUS, PFL, AFTER PAN, LAST SOLO, SOLO
SCENE, CH, EQ, DYNAMICS, EFFECT, STORE, RECALL, MEMORY, CURSOR, ENTER	IN, OUT, GR, THR, RATIO, O. GAIN, ATK, KNEE, ON, TYPE, DYNAMICS, REL, KNEE, ON, TYPE, DYNAMICS, LO, MID, LFF, HPF, EQ ON	REL, KNEE, ON, TYPE, DYNAMICS, HI, LO, MID, LFF, HPF, EQ ON, LO, MID, LFF, HPF, EQ ON	TO LEVEL, FROM LEVEL, SOLO

The 02R provides all the familiar features of a traditional analog mixer channel strip, but with the digital convenience and flexibility of scene storage and recall, EQ, dynamics, channel and effects libraries, full onboard automation with off-line editing functions, and much more.

WHAT'S NEW



24-bit Recording

- 24-bit recording provides high-resolution digital audio using two recorder tracks per channel, where a single slot can output up to four channels during recording, and track signals are automatically recombined and fed to the 02R during playback.

- Touch sense fader edit lets you instantly update a fader by simply moving it. This is only one of the convenient features you can activate using the Preferences page.
- Timecode offset lets you move Automix events back or forward relative to the incoming timecode, while timecode "capture" lets you designate up to eight locate points.

Surround Pan

- Surround pan functions support 2+ 2, 3+ 1 and 3+ 2+ 1 (5. 1) modes, to let you move sounds freely around a two-dimensional sound space, or along preset circle, ellipse, semicircle, or diagonal trajectories. Surround channels can be transferred directly to a digital multitrack recorder via YGDAI or output via the analog Aux sends.

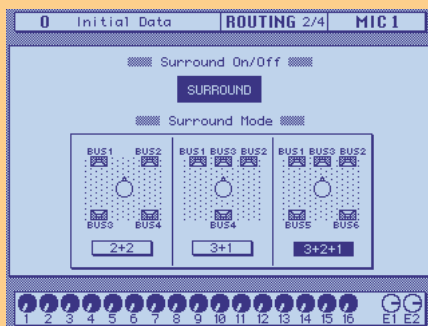

I/O Assign

- The Input Patching function lets you freely select the signal sources for MIC/LINE channels 1 to 24 and TAPE channels 1 to 16. Also, the same source can be selected for several channels, while bus outs can be patched back through to the TAPE input channels for bus out monitoring and easy fader subgrouping. This is especially convenient for live performance mixing.



Auto Mix

- Off-line editing enhancements provide faster data input with features that include copy and paste of fader, channel, pan, EQ and other Automix events, level trimming of selected parameters for selected channels between In Time and Out Time points, plus options for automatically writing new level and other data to the end of the song even after stopping playback.

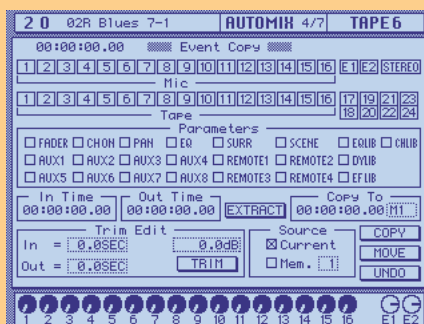

- A new Slot Output Select page lets you individually select bus outs, Aux sends, channel direct outs, and the left and right channels of the stereo output for YGDAI (Yamaha General Digital Audio Interface) digital outputs, which allows the final mixdown to be conveniently recorded onto two tracks of an MDM. When combined with the 24-bit recording mode, a full 24-bit mixdown can be recorded onto four tracks of any 16-bit MDM.
- Aux sends can be sent to the digital outputs on any YGDAI slot, providing digital aux send capabilities. Aux output select features let you send the busses directly to the 6 analog Aux sends, which is also ideal for surround monitoring as well as for output to live multi-speaker systems.

MIDI

- MIDI control assign functions let you assign 02R fader, channel, panpot, balance, EQ, effect, surround and other parameters to MIDI Control Changes, so that 02R mix settings can be controlled in real time from other MIDI devices such as a synthesizer with assignable sliders. A Scene Memory to Program Change Table simplifies configuration of Program Change options.

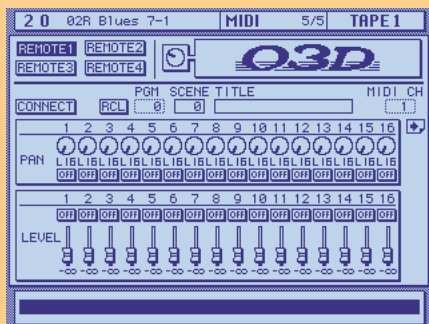

- The MIDI remote function lets you control other MIDI devices via the 02R's motorized faders, rotary encoders, ON and MIC/LINE SEL 1-16 buttons, cursor buttons and encoder wheel. Since MIDI remote operations are recorded by the Automix, real time adjustments to connected MIDI devices can be automated. There are specific MIDI remote pages for Yamaha Programmable Mixer 01, 02R and 03D digital mixers, Yamaha ProR3 and REV500 digital effects processors, GM and XG tone generators, MIDI Machine Control and Pro Tools®.
- Bus and Aux masters can be controlled from the 02R's motorized faders.
- MIDI clock sync lets the Automix be referenced to an external MIDI clock (in addition to SMPTE and MTC), while MTC to MIDI IN provides for perfect synchronization with external software or hard disk recorder.

Built-in Convenience

- Reverse and normal Phase, and Attenuation functions of stereo input channels 17 to 24 and MIC/LINE or TAPE channels configured as stereo pairs are not linked, and therefore can be adjusted independently.

- Input channels configured as a stereo pair can be routed individually. Adjacent channels of the eight Bus Outs can be paired just like the six Aux Outs.

- A channel's level within a fader group can be quickly adjusted by simply holding the SEL key and moving the fader. The Touch Sense Select option provides fast and intuitive operation by allowing a channel to be selected by simply moving its fader.

- The number of scene memories has been increased to 96, and a Clear function is now provided for channel, EQ, dynamics and effects libraries as well as mix scenes.

- Talkback cue level control lets you determine the level to which cue outputs are dimmed when talkback is engaged.

- Adjacent MIC/LINE or TAPE channels configured as a stereo pair can be used to decode signals derived using MS microphone techniques.

- The fader start and stop function transmits a MIDI Note On message when channel faders are raised from infinity, and a Note Off message when faders are moved back to infinity. This lets you automatically start and stop DAT, MD, CD and other players via fader movements (with interface box from third parties).

- Initial data options let you choose whether all faders will be set to nominal or minimum positions when scene memory 0 is recalled.

- Input channel delay on/off control is now possible from the View screen, and Auto WORD CLOCK Display and Pre EQ Direct Out have been added to the general Preferences page.

- Multiple 02R control options provide simplified control of two or more cascaded 02Rs by a master 02R, of automix, scene store and recall functions, and more. This conveniently allows for configurations of two or more 02Rs to function as one large digital mixing console. Automix and scene memory functions, including storing, recalling and naming are linked together to behave as one integrated system.

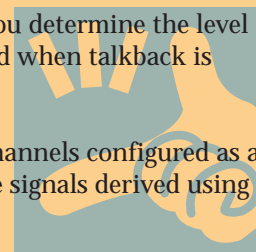

Convenient Open "Slot" System

The 02R is designed for maximum compatibility with all major industry-standard digital audio formats. Simply plug the appropriate I/O interface card (8 channels per card) for your specific recorder into any of the 4 YGDAI (Yamaha General Digital Audio Interface) slots located on the rear panel. Choose the interface (see chart, below) according to the number of tracks you have, and feel free to mix card types at will.

Although an AD/DA interface (8 channels per card) using high-performance 20-bit converters is available for connection to analog MTRs, you can also bus analog signals out using the Aux sends.

Input/Output of Each Slot

Slot	Input	Output
1	TAPE IN 1-8	BUS 1-8 or DIRECT OUT MIC/LINE 1-8 (by ROUTING SW), AUX1-6, STEREO
2	TAPE IN 9-16	BUS 1-8 or DIRECT OUT MIC/LINE 9-16 (by ROUTING SW), AUX1-6, STEREO
3	MIC/LINE 1-8	BUS 1-8, AUX1-6, STEREO
4	MIC/LINE 9-16	BUS 1-8, AUX1-6, STEREO

I/O Card Height and Pluggable Slots

Card	Height	Slot
CD8-TDII	Single	for all 1 ~ 4, 4 cards/32ch max.
CD8-AT	Single	for all 1 ~ 4, 4 cards/32ch max.
CD8-Y	Single	for all 1 ~ 4, 4 cards/32ch max.
CD8-AE	Double	for all 1 ~ 2, 2 cards/16ch max.
CD8-AES	Single	for all 1 ~ 4, 4 cards/32ch max.
CD8-AD	Double	1 or 2, 2 cards/16ch max.
CD8-CS KIT	Single(X2 & cable)	any of 1 ~ 4, usually 3 or 4

*Card types can be mixed.

40 Inputs, 8 Busses & 8 Aux Sends

24 analog inputs and 16 digital inputs provide for 40 channel inputs, with 16 of the 24 analog inputs incorporating high-performance head amplifiers for optimum matching with microphone or line sources.

Channels 1 to 8 feature balanced XLR connectors with phantom power built-in, TRS phone jacks (with A/B switching between XLR and TRS inputs) and insert patch points. Channels 9 to 16 are provided with balanced TRS phone jack inputs.

These 16 channels can also be configured for digital inputs (TASCAM, ADAT, AES/EBU or YAMAHA format) to provide a total of 32 channels available for digital mixdown. Channels 17/18 to 23/24 are conveniently configured to accept line-level stereo sources.

The 16 digital input channels (TAPE 1-16) can accept digital input in TASCAM, ADAT, AES/EBU or any YAMAHA digital audio format. Simply adding an optional AD/DA interface permits output from analog MTRs to be returned to these channels for full 40-channel analog input capability.

Other channel controls include 20dB pad switches on channels 1 to 16, detented trim controls (+ 16 to -60dB on channels 1 to 16; + 4 to -40dB on channels 17 to 24), peak/signal indicators, phase switches, programmable channel delay up to 60ms, and direct outputs on channels 1 to 16.

Eight auxiliary sends provide for versatile signal routing. AUX 5 and 6 can be used individually or as a stereo control room or studio monitor send, or as a performer's cue mix send during recording. AUX 7 and 8 feed internal high-performance digital effect processors, and can be connected in series for flexible effects configuration. Pre- or post-fader operation is possible with each send, while sends 1/2, 3/4, and 5/6 can be paired in stereo, depending on your requirements.

Two pairs of 2-track analog inputs (balanced TRS phone and unbalanced RCA type jacks) and 3 stereo 2-track digital inputs (one AES/EBU and two COAXIAL S/P DIF inputs) provide for highly versatile input routing. Two of the digital inputs can easily be routed to stereo input channels 17/18 and 19/20 for recording or mastering applications.

Multiple 02R consoles can be cascaded at will for increased input capacity. Version 2 software simplifies control of scene, automix and other functions on all consoles from the "master".

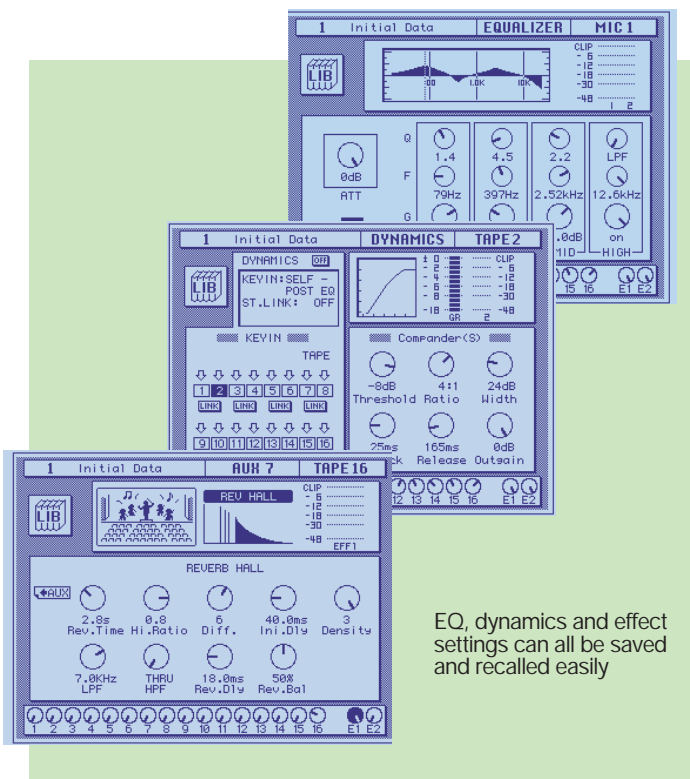

Versatile Processing On All Inputs

The 02R's on-board digital effects processors can be applied to all 40 channel inputs and the 2 stereo effect returns. The 4-band fully parametric EQ can be applied to all inputs, including analog inputs 1 to 24, digital tape inputs 1 to 16, and stereo effect returns 1 and 2.

The LOW, LOW-MID, HIGH-MID, and HIGH bands all allow boost/cut over a $\pm 18\text{dB}$ range, sweepable from 20 Hz to 20kHz, with a 41-point Q range. Depending on your requirements, the LOW and HIGH bands can be used in shelving or HPF/LPF filters. The graphic display on the console's large LCD provides for ample visual feedback.

Dynamics processing can be applied to all 40 input channels, with five processor types which are individually selectable for each channel, including compressor, gate, expander, ducking, and a combined compressor/limiter/expander. Key-in and stereo link functions provide for added flexibility, while individual processing on each channel offers the same type of extensive dynamics control as extremely expensive high-end studio consoles.

There are plenty of preprogrammed EQ, dynamics, and effect libraries, and all user settings can be saved in a large user memory area for instant recall at the touch of a button. These settings can be applied as events within an automation program, while an "undo" function instantly recalls the settings prior to a save operation. With the 02R, convenience and flexibility is built right in.

Up to four fader groups—where a single fader controls multiple specified faders—and four mute groups, can be designated in a flash to permit convenient control of multi-source "sections" for enhanced operation, ease and efficiency. Version 2 software lets you make adjustments to one or more channels on-the-fly.

Convenient handling of stereo signals is possible since EQ and other channel parameters for adjacent channels (MIC/LINE 1 to 16, TAPE 1 to 16) can be linked for simultaneous control, and panning can be independent or linked.



Interactive Interface

Interactive Interface With Multi-function 100 mm Motor Faders

The SELECTED CHANNEL section works in conjunction with the large 320 x 240 pixel backlit LCD screen and navigation and data entry section to make routing, auxiliary send level, pan, and EQ adjustment simple and intuitive. Interactive displays are called up automatically while you work, and a View screen displays all parameters for the selected channel. A handy "channel library" function lets you save all settings for a single channel and recall them at will. Copying data from a source channel to any other specified channel is as easy as the flick of a switch.

The 100mm multi-function motorized faders provide precise control of input and effect send and return and other levels, while the FLIP key lets you interchange the functions of the linear faders and rotary encoders on channels 1 to 16 for MIC/LINE or TAPE level control.

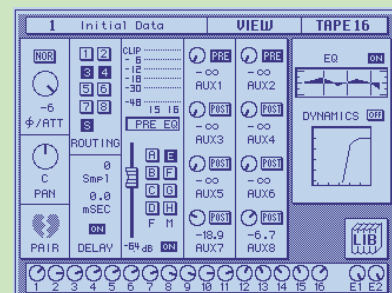

"View" Screen

Versatile Output & Monitoring Functions

The 02R comes standard with a variety of output options, including both COAXIAL (S/P DIF) and AES/EBU digital stereo outputs, and balanced XLR and unbalanced RCA analog stereo outputs, with full 4-band parametric EQ included in the stereo output stage.

Dynamics processing can be applied to the 8 bus outputs as well as the stereo outputs, and both individual track processing and overall compression can be applied if the situation requires.

The monitor section includes studio and control room monitor outputs, each with individual level control. In addition to the 2-track inputs and stereo bus, auxiliary sends 5 and 6 are ideal for setting up a performer's cue mix.

The solo signal is sent to only the control room monitor outputs in recording solo mode, and to the main outputs in mixdown solo mode. The solo signal can be taken either pre-fader or post-pan. In addition to the normal summing solo mode, a "last solo" mode is available for monitoring of the last pressed solo switch signal. In the mixdown solo mode a solo-safe function for all input channels is provided for monitoring of soloed channel plus related effects.

A built-in oscillator with 100 Hz, 1kHz and 10kHz sine wave output, plus white noise, can be routed to the 8 bus outputs, the stereo outputs, and/or the 8 auxiliary outputs.

Full On-board Automation

The 02R comes equipped with full on-board automation of all faders (including the Aux send faders) as well as all mixing parameters. Recording and mixdown automation can be synchronized to external SMPTE timecode (30f, 30df, 25f, 24f) or MIDI timecode, and MIDI clock sync lets the Automix be referenced to an external MIDI clock.

Dynamic real time automation is available for the faders, channel on/off switching, panning, EQ and surround sound parameters. On-line editing options include "absolute" mode where the written fader data corresponds precisely to the fader positions, and "relative" mode where previously written data can be trimmed according to your needs. A "motor off" function can be engaged to stop fader movement for simple control in the relative Automix mode.

96 scene memories are provided for storing "snapshots" of all fader and parameter settings, which can be treated as Automix events. Off-line editing functions permit scene memory, EQ, dynamics processor, effect and channel library recall to be specified in precise frame increments. Easy copy and paste of selected parameters for selected channels between In Time and Out Time points is possible, while a Write To End feature automatically writes new level and other data to the end of the song even after stopping playback. A fader recall safe function lets you specify which faders will be unaffected by snapshot recall for convenient manual control.

Although about 0.5MB of automation memory is supplied as standard equipment from the factory, up to two optional 1 MB expansion cards can be added to increase the memory to 2.5 MB (maximum). Version 2 also employs data compression techniques which effectively increase Automix storage capacity by 50%.

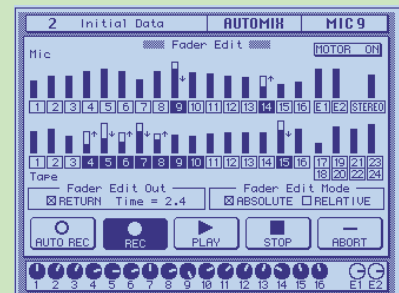
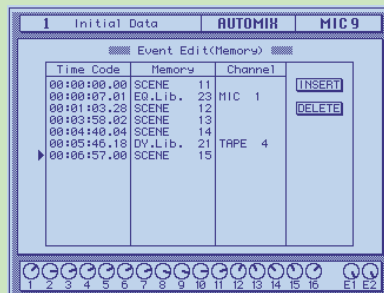
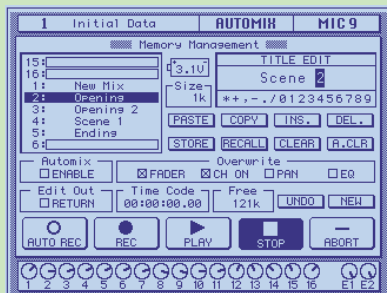

Displays for Automixing Operation

External MIDI Or Direct Computer Control

The 02R's MIDI IN, OUT, THRU and MTC IN terminals permit flexible control of—as well as control by—external MIDI devices. 02R scene memories and programs can be switched from external devices using MIDI Program Change numbers, while system exclusive data can be used for precise sequence control of all mixing parameters.

An external synthesizer's assignable sliders can be used to select 02R fader, channel, panpot, balance, EQ, effect, surround and other parameters via MIDI Control Change messages.

The MIDI remote function lets you control other MIDI devices via the 02R's faders, rotary encoders, ON and MIC/LINE SEL 1-16 buttons, cursor buttons and encoder wheel—all recordable with the Automix.

Specific MIDI remote pages for Yamaha 02R and 03D digital mixers, Yamaha ProR3 and REV500 digital effects processors, GM and XG tone generators, MIDI Machine Control and Pro Tools® provide convenient control of a wide variety of external devices from the on-board controls. Bus and Aux masters can be controlled from the 02R's motorized faders.

A "TO HOST" RS422 port is also provided to allow direct control from a personal computer running appropriate software.

Twin RISC CPUs & 32-bit Processing

Yamaha custom-developed 32-bit signal processing LSIs and twin RISC CPUs provide unprecedented sound quality and fast response speed.

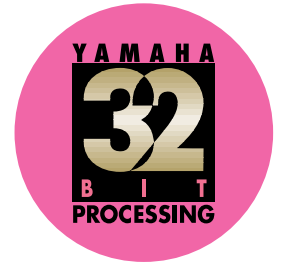

20-bit AD/DA Converters

High-precision, high-resolution 20-bit linear AD converters with 64-times over-sampling are available on all analog inputs. 20-bit linear DA converters with 8-times over-sampling are featured on the stereo and control room monitor outputs.

With a dynamic range of 110dB at the stereo outputs and 105dB from the MIC/LINE inputs to the STEREO OUT connectors, the 02R is capable of providing uncompromising sound quality in the most demanding professional recording and mixing situation.



Rear Panel



Rear panel of 02R shown with the optional TASCAM & ADAT Interface Cards installed.

O2R Block Diagram

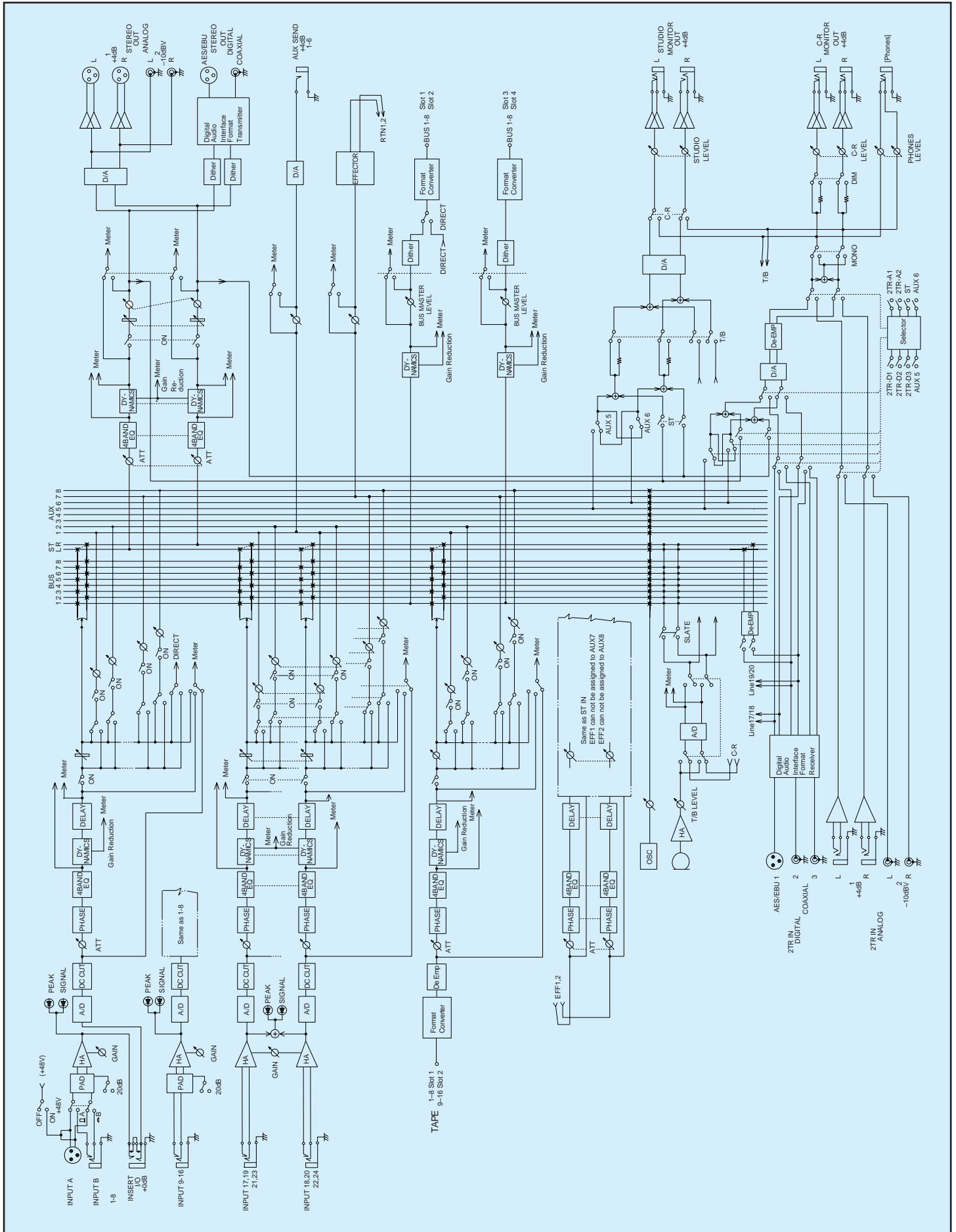

02R Library List

■ Equalizer

1	Bass Drum 1	Emphasizes the low range of the bass drum and the attacked created by the beater
2	Bass Drum 2	Creates a peak around 80Hz, producing a tight stiff sound.
3	Snare Drum 1	Emphasizes snapping and rimshot sound.
4	Snare Drum 2	Emphasizes the ranges of that classic rock snare drum sound.
5	Tom-Tom 1	Emphasize the attack of tom-toms, and creates a long "leathery" decay.
6	Cymbal	Emphasizes the attack of crash cymbals, extending the "sparkling" decay.
7	High Hat	Use on a tight high-hat, emphasizing the mid to high range.
8	Percussion	Emphasizes the attack and clarifies the high-range of instruments, such as shakers, cabanas, and congas.
9	E. Bass 1	Makes a tight electric bass sound by cutting very low frequencies.
10	E. Bass 2	Unlike program 9, this emphasizes the high range of the electric bass.
11	Syn.Bass 1	Use on a synth bass with emphasized low range.
12	Syn.Bass 2	Emphasizes the attack that is peculiar to synth bass.
13	Piano 1	This is used to make a piano sound brighter.
14	Piano 2	Emphasizes the attack and low range of the piano sound by using a compressor.
15	E.G Clean	Use for line-recording an electric guitar or semi-acoustic guitar to get a slightly hard sound.
16	E.G. Crunch 1	Adjusts the tonal quality of a slightly distorted guitar sound.
17	E.G. Crunch 2	This is a variation on program 16.
18	E.G. Distortion 1	Makes a heavily distorted guitar sound clearer.
19	E.G. Distortion 2	This is a variation on program 18.
20	A.G. Stroke 1	Emphasizes the bright tones of an acoustic guitar.

21	A.G. Stroke 2	This is a variation on program 20. You can also use it for the electric gut guitar.
22	A.G. Arpeggio 1	Corrects arpeggio technique of an acoustic guitar.
23	A.G. Arpeggio 2	This is a variation on program 22.
24	Brass Section	Use with trumpets, trombones, or sax. With one instrument, adjust the HIGH or MID frequency.
25	Male Vocal 1	Use as a template for male vocal. Adjust the HIGH or H-MID setting according to the voice quality.
26	Male Vocal 2	This is a variation on program 25.
27	Female Vocal 1	Use as a template for female vocal. Adjust the HIGH or H-MID setting according to the voice quality.
28	Female Vocal 2	This is a variation on program 27.
29	Chorus & Harmony	Use as a template for a chorus. It makes the entire chorus much brighter.
30	Total EQ 1	Use on the STEREO bus during mixdown. For more effect, try it with a compressor.
31	Total EQ 2	This is a variation on program 30.
32	Total EQ 3	This is a variation on program 30. Also use these programs for stereo inputs or external effect returns.
33	Bass Drum 3	This is a variation on program 1, the low and mid range is removed.
34	Snare Drum 3	This is a variation on program 3. It creates rather thick sound.
35	Tom-Tom 2	This is a variation on program 5. Emphasizes the mid and high range.
36	Piano 3	This is a variation on program 13.
37	Piano low	Use for the low range of the piano sound when it is recorded in stereo. Use with program 38.
38	Piano high	Use for the high range of the piano sound when it is recorded in stereo. Use with program 37.
39	Fine-EQ (Cass)	Use for recording to or from cassette tape to make the sound clearer.
40	Narrator	Use for recording a voice reading a text.

■ Dynamic Processor

1	A.Dr BD	"CMP"	Compressor that gives the best result with as acoustic bass drum.
2	A.Dr.BD	"EXP"	Expander for the same purpose as program 1.
3	A.Dr.BD	"GAT"	Gate for the same purpose as program 1.
4	A.Dr. BD	"CPH"	Hard compander for the same purpose as program 1.
5	A.Dr. SN	"CMP"	Compressor that gives the best results with an acoustic snare drum.
6	A.Dr.SN	"EXP"	Expander for the same purpose as program 5.
7	A.Dr.SN	"GAT"	Gate for the same purpose as program 5.
8	A.Dr.SN	"CPS"	Soft compander for the same purpose program 5.
9	A.Dr.Tom	"EXP"	Expander for acoustic toms automatically reduces the volume when the toms are not played, helping to differentiate the bass and snare clearly.
10	A.Dr.OverTop	"CPS"	Soft compander to emphasize the attack and ambience of cymbals using overhead microphone. It automatically reduces the volume when the cymbals are not played, helping differentiate the bass and snare drums clearly.
11	E.B.finger	"CMP"	Compressor to equalize the attack and volume level of a finger-picked electric bass guitar.
12	E.B.slapp	"CMP"	Compressor to equalize the attack and volume of a slap electric bass guitar.
13	Syn.Bass	"CMP"	Compressor to adjust and/or emphasize the level of a synth bass.
14	Piano 1	"CMP"	Compressor to brighten the tonal color of a piano.
15	Piano 2	"CMP"	A variation on program 14, adjusting the attack and entire level using a deeper threshold.
16	E. Guitar	"CMP"	Compressor for backing performance, such as electric rhythm guitar playing chords or arpeggios.
17	A. Guitar	"CMP"	A variation on program 16, intended for acoustic guitar playing rhythm chords or arpeggio.
18	Strings 1	"CMP"	Compressor for string instruments. this program was intended for violins.
19	Strings 2	"CMP"	A variation on program 18, intended for violas or cellos.
20	Strings 3	"CMP"	A variation on program 18, intended for string instruments with a very low range, such as cellos or contrabass.

21	Brass Section	"CMP"	Compressor intended for brass sounds with fast and strong attack.
22	Syn.Pad	"CMP"	Compressor for synth pad, intended to prevent diffusion of the sound.
23	SamplingPerc	"CPS"	Compressor for sampled sounds to boost them to be as powerful and clear the acoustic sounds. This is for percussion sound.
24	Sampling BD	"CMP"	A variation on program 23, intended for sampled bass drum sound.
25	Sampling SN	"CMP"	A variation on program 23, intended for sampled snare drum sounds.
26	Hip Comp	"CPS"	A variation on program 23, intended for sampled sounds for loops.
27	Solo Vocal 1	"CMP"	Compressor suited for a solo vocal source.
28	Solo Vocal 2	"CMP"	A variation on program 27.
29	Chorus	"CMP"	A variation on program 27, intended for chorus vocals.
30	Compander(H)	"CPS"	A template for the hard knee compander program.
31	Compander(S)	"CPS"	A template for the soft knee compander program.
32	Click Erase	"EXP"	Expander to remove click track sounds that may bleed out of the monitor headphones the musicians are using.
33	Announcer	"CPH"	Hard compander reduces the level during the interval between the words, making the voice sound even.
34	Easy Gate	"GAT"	A template for the gate program.
35	BGM Ducking	"DUK"	Ducking background music for voice-overs, typically keyed from the announcer's channel.
36	Limiter 1	"CMP"	A template for a limiter using the soft compander program. This program has a slow release.
37	Limiter 2	"CMP"	A template for a limiter using the compressor program. This program is a PEAK STOP type.
38	Total comp	"CMP"	Compressor intended to reduce the overall volume level. Use for the stereo out during mixdown. It is also interesting on stereo input signals.
39	Total Comp 2	"CMP"	A variation of program 38. It has a harder compression ratio.
40	Total Comp 3	"CMP"	A variation of program 38. It has an extreme compression ratio, almost a limiter effect.

CMP: Compressor, GAT: Gate, DUK: Ducking, EXP: Expander, CPH: Compressor+Limiter+Expander Hard, CPS: Compressor+Limiter+Expander Soft

■ Effect Programs

1	Reverb Hall 1	This simulates the reverberation in a larger concert hall, and adds spread to sounds such as strings and brass.
2	Reverb Hall 2	This is a variation on program 1. It emphasizes longer reverberation and spaciousness.
3	Reverb Room 1	This simulates reverberation of a room with many reflective wall aspects. It gives a live acoustic feel to drums.
4	Reverb Room 2	This is a variation on program 3.
5	Reverb Stage	This has a slightly brighter effect than the Reverb Hall Programs. Applying a small amount of this effect to an entire mix will create the feel of live acoustic environment.
6	Reverb Plate	This simulates an old "Steel plate reverb" and is effective on vocals or musical instruments, especially percussion.
7	REV Ambience 1	This creates space (a smaller space than created by the Reverb Room Programs) around instruments. A small amount of these effects is effective on vocal and chorus, as well as percussion instruments.
8	REV Ambience 2	This is a variation on program 7.
9	REV Live Room 1	This simulates reverberation in much larger rooms.
10	REV Live Room 2	This is a variation on program 9.
11	Reverb Vocal 1	This is useful for vocal and chorus.
12	Reverb Vocal 2	This has longer reverberation than program 11. This could be suitable for ballads.
13	REV SN.Room	This is a reverb variation to enhance the sound of a snare drum.
14	REV SN.Plate	This is also for snare drums, similar to program 13.
15	Chorus->Reverb	Stereo chorus followed by reverb. This program will change a dry sound into a warm sound with spread. Use the reverb Depth parameter to adjust the amount of reverberation.
16	Flange->Reverb 1	Flange effect by reverb. This effect is more appropriate to emphasize modulation effects than the CHORUS-REVERB program. Use the reverb Depth parameter to adjust the amount of reverberation.
17	Flange->Reverb 2	This is a variation on program 16.
18	Early REF. 1	Simulates early reflections only. It can create a wide range of effects, from gate-reverb to ambience effects.
19	Early REF. 2	This is a variation on Program 18. It produce a thicker sound.
20	Gate Reverb	Simulates a gate reverb effect by using the EARLY REFLECTION program.

21	Reverse Gate	This is a variation on program 20. It creates somewhat strange, reversed gate reverb sound.
22	DELAY->Early REF.	This effect creates early reflection sound after a delay.
23	Delay L-C-R 1	A three-part delay with independent delay time parameters for left, right, and center.
24	Delay L-C-R 2	This is a variation on program 23.
25	Chorus->DLY LCR	Chorus effect is followed by three-part delay(L-C-R) with feedback.
26	Mono DLY->Chorus	Mono feedback delay followed by stereo chorus.
27	Stereo INI.DLY ECHO	Stereo feedback delay followed by stereo echo.
28	Echo	This is a common echo effect.
29	Cross Echo	The Echo feedback signal crosses left to right and from right to left.
30	Cross Delay	The Echo feedback signal crosses completely.
31	Chorus 1	A stereo chorus. Creates rich, thickening effect.
32	Chorus 2	This is a variation on program 31. The modulation is much thicker and shimmering.
33	Broad Chorus	This is a variation on program 31, with more spread and spaciousness.
34	Flange	Stereo Flanger. Creates a rich, swirling effect, full of harmonics.
35	Symphonic	This program creates a rich grand chorus effect, bigger than chorus alone.
36	Tremolo	A Stereo tremolo, just like on a classic guitar amplifier. It creates a fat sound that is great with guitars.
37	Auto PAN	This effect performs automatic panning across the stereo image.
38	Phasing	Stereo Phaser. This effect simulates old phase shifter effects.
39	ST.Pitch Change	Two-Part stereo pitch shifter. This stereo effect changes the pitch of the left and right channels independently of each other.
40	Vocal Doubler	This is a thin harmonizing effect obtained by setting a longer delay.

Specifications

General Specifications

Total Harmonic Distortion	less than 0.2% 20Hz~20kHz(analog output) @+14dB into 600Ω
Frequency Response*1	+1, -3dB, 20Hz~20kHz @+4dB into 600Ω
Dynamic Range*1	110dB(typical) DA Converter(STEREO OUT) 105dB(typical) AD to DA(MIC/LINE IN to STEREO OUT)
Hum & Noise Level*1*2	-128dB Equivalent Input Noise(20Hz~20kHz) Rs=150W, Input Gain=Max., Input Pad=0dB, Input Sensitivity=-60dB
Crosstalk @1kHz	70dB adjacent input channels 70dB input to input
AD Conversion	20-bit linear 64 times oversampling(INPUT 1~24)
DA Conversion	20-bit linear 8 times oversampling(ST OUT, C-R MONI OUT) 18-bit linear 8 times oversampling (STUDIO MONI OUT, AUX SEND 1~8)
Internal Signal Processing	32-bit(Dynamic Range=192dB)
Sampling Frequency	Internal:44.1/48kHz External:32kHz(-6%)~48kHz(+6%)
Equalizer	4-band Full Parametric Equalization f:20Hz~20kHz(120point), G:±18dB(0.5dB step), Q:0.1~10(41point)——4-stages type:shelving/filter——LOW, HIGH (40 IN, Internal EFF RTN 1, 2, ST OUT)
Fader	100mm Motor Fader x21
Memory	Scene(Total Recall) 96 Ch Library 64 EQ Library 128(40 preset) Dynamics Library 128(40 preset) Effect Library 128(40 preset) Auto mix 16(0.5MB)
Display	320x240 pixel backlit LCD panel
Stereo Meter	21-elements x2 LED
Dimensions & Weights	662.7(700.7*3)W x 221.5(334.9*4)H x 685(691.5*4)D mm 30kg

*1=fs:internal 48kHz

*2=measured with a 6dB/octave filter @12.7kHz(equivalent to a 20kHz filter with infinite dB/octave attenuation).

*3=W02SP(1.7kg) attached.

*4=MB02(3kg) connected.

TEAC, TASCAM are registered trademarks of TEAC Corporation.
ADAT, ALESIS are registered trademarks of Alesis Corporation.
ADAT Digital Interface is a trademark of Alesis Corporation.
Foxtex is a trademark of Foxtex Corporation.
*Specifications and appearance subject to change without notice.

Dimensions

Unit : mm

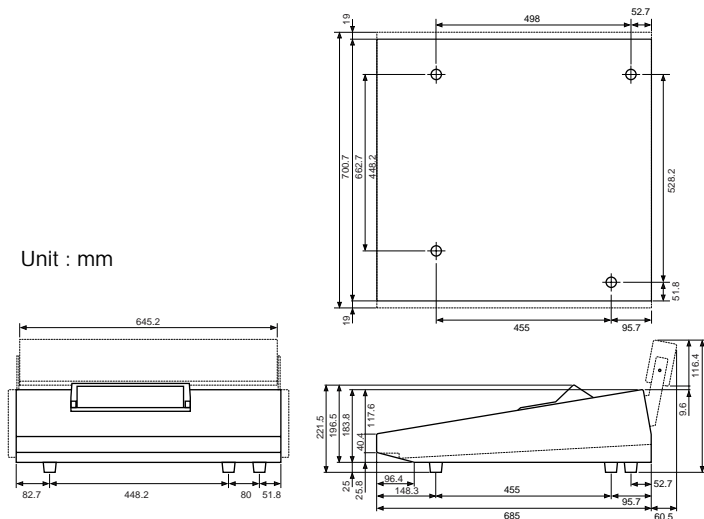

Analog Input/Output Characteristics

Input Terminals	Pad	Gain	Actual Load Impedance	For Use with Nominal	Input Level			Connector
					Sensitivity*1	Nominal	Max. before Clip	
CH INPUT MIC/LINE 1-16 A:1-8 B:1-16	0	-60	A:3kΩ B:4kΩ	50~600Ω Mics & 600Ω Lines	-70dB (0.245mV) -26dB (38.8mV) -6dB (388mV)	-60dB (0.775mV) -16dB (0.123V) +4dB (1.23V)	-40dB (7.75mV) +4dB (1.23V) +24dB (12.3V)	A:XLR-3-31 type* or B:TRS Phone Jack* ^B
		-16						
CH INPUT LINE 17-24		-40	4kΩ	600Ω Lines	-50dB (2.45mV) -6dB (388mV)	-40dB (7.75mV) +4dB (1.23V)	-20dB (77.5mV) +24dB (12.3V)	TRS Phone Jack* ^B
		+4						
INSERT IN MIC/LINE 1-8			10kΩ	600Ω Lines	-10dB (245mV)	+0dB (0.775V)	+20dB (7.75V)	TRS Phone Jack* ^U
2TRACK INPUT(L, R)			10kΩ	600Ω Lines	+4dB (1.23V) -10dBV (316mV)	+4dB (1.23V) -10dBV (316mV)	+24dB (12.3V) +10dBV (3.16V)	TRS Phone Jack* ^B RCA Pin Jack* ^U

Output Terminals	Actual Source Impedance	For Use with Nominal	Output Level		Connector
			Nominal	Max. before Clip	
STEREO OUT(L, R)	150Ω	600Ω Lines	+4dB (1.23V)	+24dB (12.3V)	XLR-3-32 type* ^B
	600Ω	10kΩ Lines	-10dBV (316mV)	+10dBV (3.16V)	RCA Pin Jack* ^U
STUDIO MONITOR OUT(L, R)	150Ω	10kΩ Lines	+4dB (1.23V)	+24dB (12.3V)	TRS Phone Jack* ^B
C-R MONITOR OUT(L, R)	150Ω	10kΩ Lines	+4dB (1.23V)	+24dB (12.3V)	TRS Phone Jack* ^B
AUX SEND 1-16	600Ω	10kΩ Lines	+4dBV (1.23V)	+20dBV (7.75V)	Phone Jack* ^U
INSERT OUT MIC/LINE 1-8	600Ω	10kΩ Lines	0dB (0.775mV)	+20dB (7.75V)	TRS Phone Jack* ^U
PHONES	100Ω	8Ω Phones	1mW	25mW	Stereo Phone Jack
		40Ω Phones	3mW	110mW	

*1 The lowest level that will produce an output of +4dB(1.23V) or the nominal level when the unit is set to maximum gain.

*B Balanced.

*U Unbalanced.

* 0dB=0.775Vrms, 0dBV=1Vrms

Digital Input/Output Characteristics

Terminals	Format	Level	Connector
STEREO OUT DIGITAL AES/EBU	AES/EBU	RS-422	XLR-3-31 type
STEREO OUT DIGITAL COAXIAL	S/P DIF *	0.5Vpp/75Ω	RCA Pin Jack
2TR IN DIGITAL 1 AES/EBU	AES/EBU	RS-422	XLR-3-32 type
2TR IN DIGITAL 2, 3 AES/EBU	S/P DIF *	0.5Vpp/75Ω	RCA Pin Jack
WORD CLOCK IN	---	TTL/75Ω	BNC
WORD CLOCK OUT	---	TTL/75Ω	BNC
TC IN	SMPTE	Nominal-10dBV/10kΩ	RCA Pin Jack
MTC IN	MIDI	---	DIN 5pin
MIDI-IN-OUT-THRU	MIDI	---	DIN 5pin
TO HOST	---	---	Mini DIN 8pin
METER	---	RS-422	D-sub 15pin

* IEC958, EIAJ CP-1201(Consumer)

For details please contact:

For more information about the 02R Digital Recording Console, other Yamaha products, dealer network and more, visit:

Yamaha PA Web Site

<http://www.yamaha.co.jp/product/proaudio/homeenglish/>

YAMAHA
YAMAHA CORPORATION
P.O.BOX 1, Hamamatsu Japan